



What Fluorescence-Mie-Raman Lidar (**FLUMIRA**) reveals about atmospheric aerosols across seasons and cities ?

Remote Sensing
Laboratory

A. Hafiz, I.S. Stachlewska

*Remote Sensing Laboratory, Institute of Geophysics,
Faculty of Physics, University of Warsaw*

afwan.hafiz@fuw.uw.edu.pl



1. Motivation

2. Instruments

- Mie-Raman Fluorescence Lidar

3. Methods

- Lidar Equations
- Datasets Categorization
- Applied constrains (focus on local aerosol, ABLH)

4. Results

- Importance of Fluorescence
- Importance of water vapor
- Typing

5. Conclusion

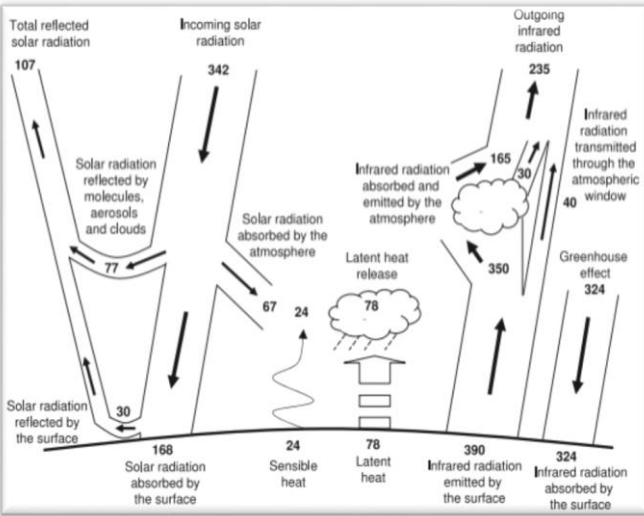

Illustration of Earth's energy budget on the surface and in the atmosphere in Wm⁻² (Boucher, 2015)

Aerosol characterization is essential for understanding:

Air quality

→ Aerosols directly affect human health and visibility.

Climate

→ Aerosol is an atmosphere components

→ Aerosols influence the Earth's radiative balance.

→ They remain a major source of uncertainty in climate forcing assessments

How can aerosol characterization be improved?

→ Lidar provides vertically resolved information on aerosols in the atmosphere.

Why Fluorescence?

Synergy of fluorescence + Mie-Raman

Improve aerosol typing

Increase sensitivity to biological aerosol

Synergy of fluorescence + water vapor + Mie-Raman, support the study:

aerosol hygroscopic growth

aerosol-cloud interactions



Introduction

Light Detection and Ranging (LIDAR)

$$d = ct/2$$

d = distance to the scatterers (m)
 c = constant speed of light ($\frac{m}{s}$)
 t = recorded time (s)

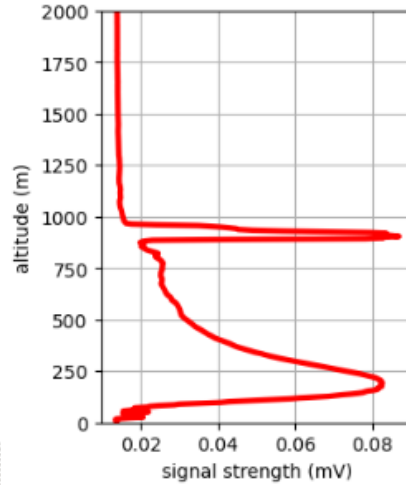
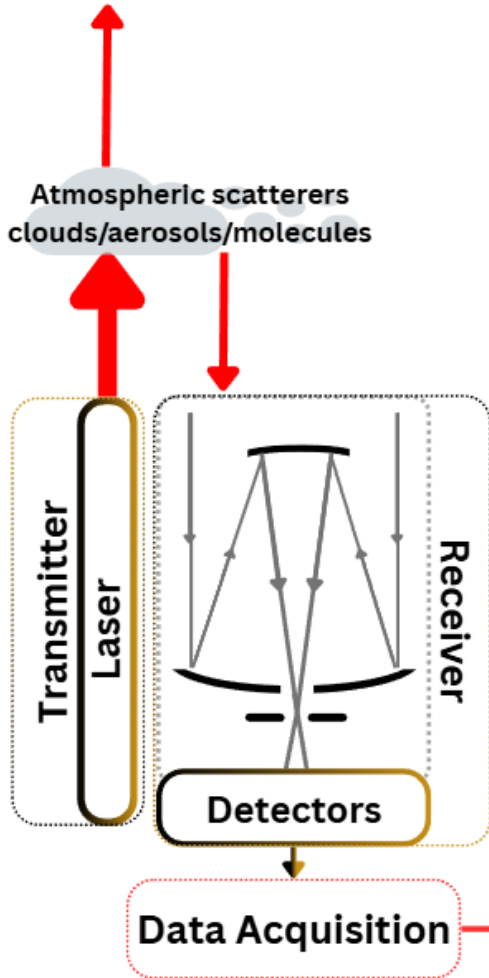

Lidar can be deployed in different platforms

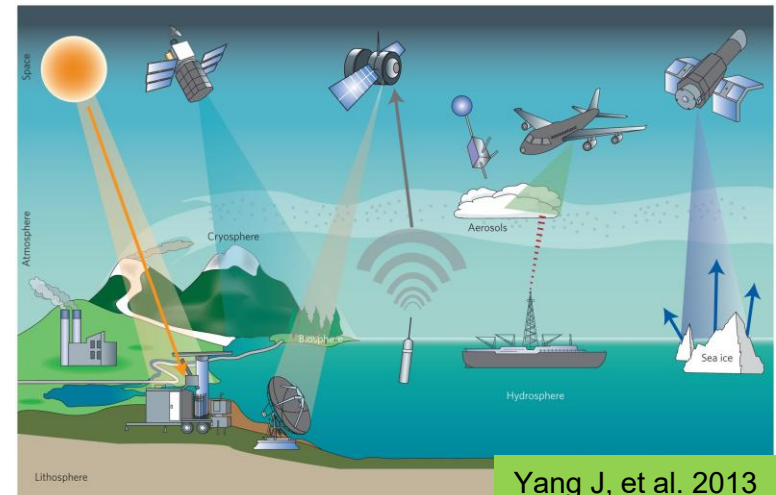

Yang J, et al. 2013



Lidar for Atmospheric Studies

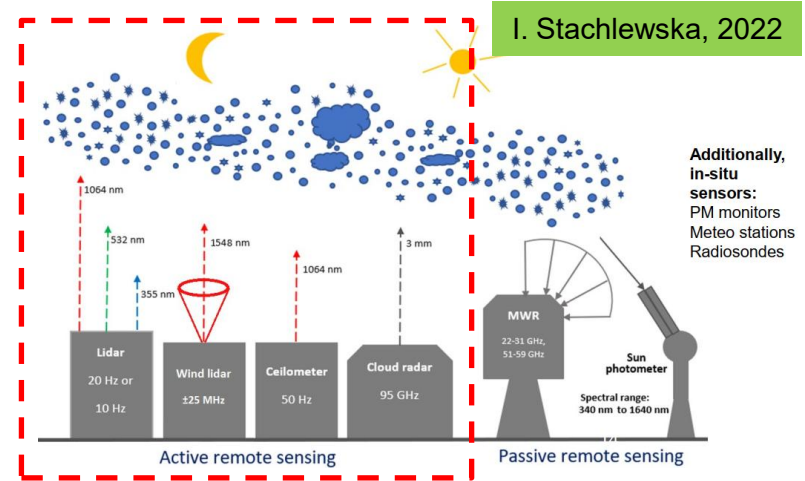

‘different interactions, different applications’

Interaction	Applications
Elastic Rayleigh & Mie Scattering	Aerosol & Cloud
Raman scattering	Nitrogen, oxygen, water vapor, temperature
Fluorescence	Organic matter in troposphere
Absorption	Gas particles (e.g. ozone)
Multiple Scattering	Clouds & fogs
Resonance Fluorescence scattering	Atoms, free-alkali, ions, molecules
Doppler Effect	Wind, turbulence, aerosols



ESA Mobile Raman Lidar (EMORAL)

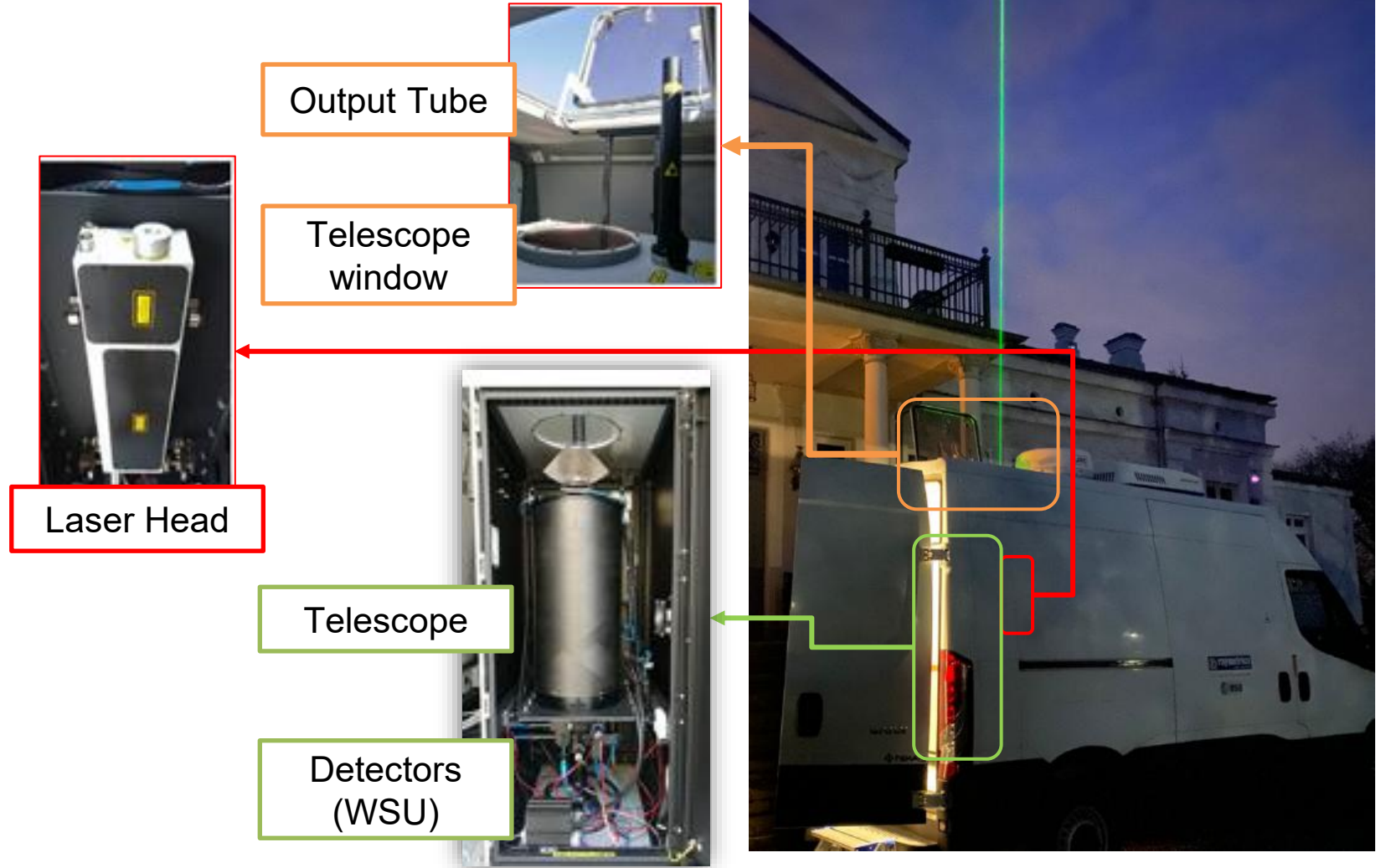



Instrument

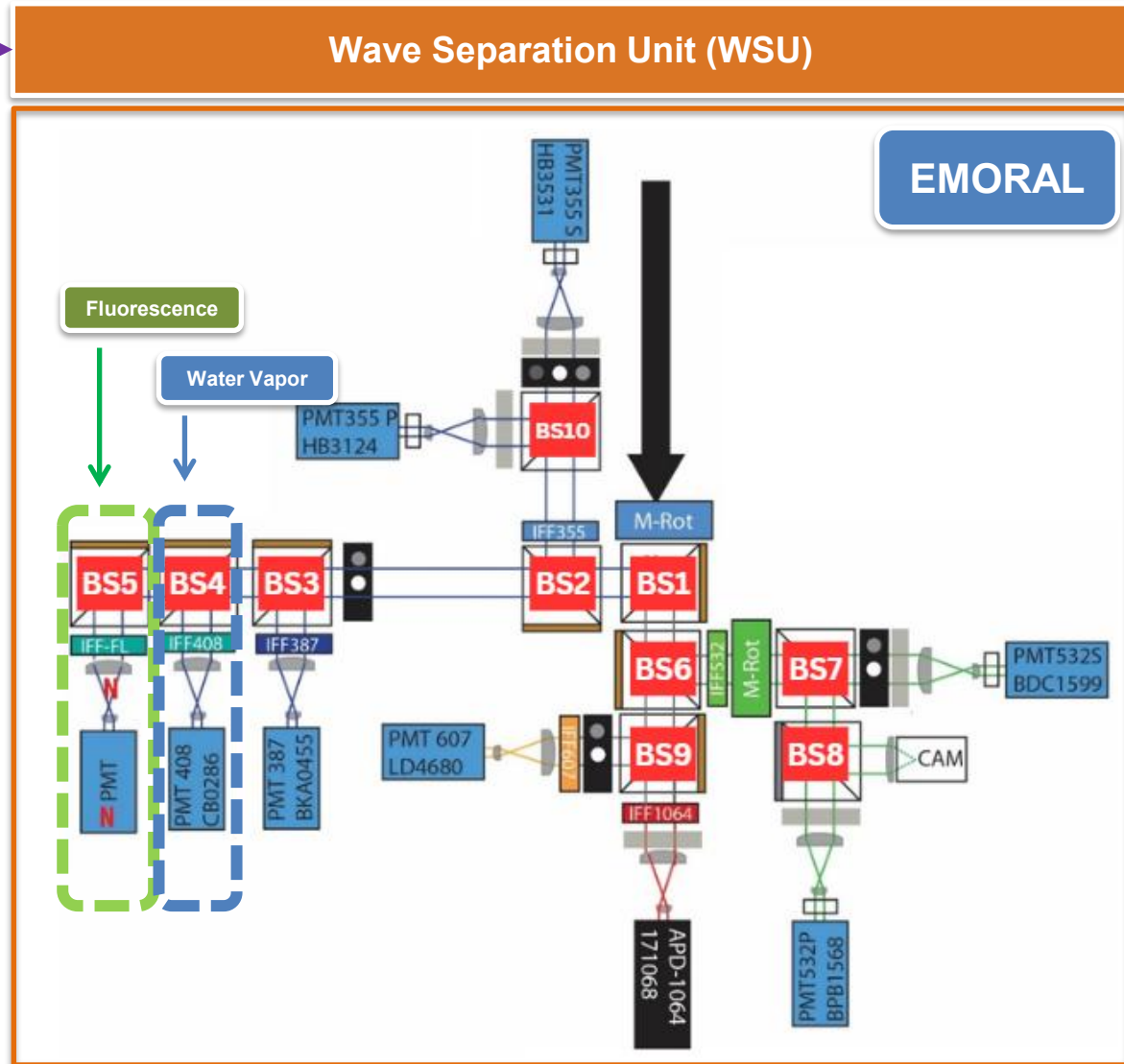
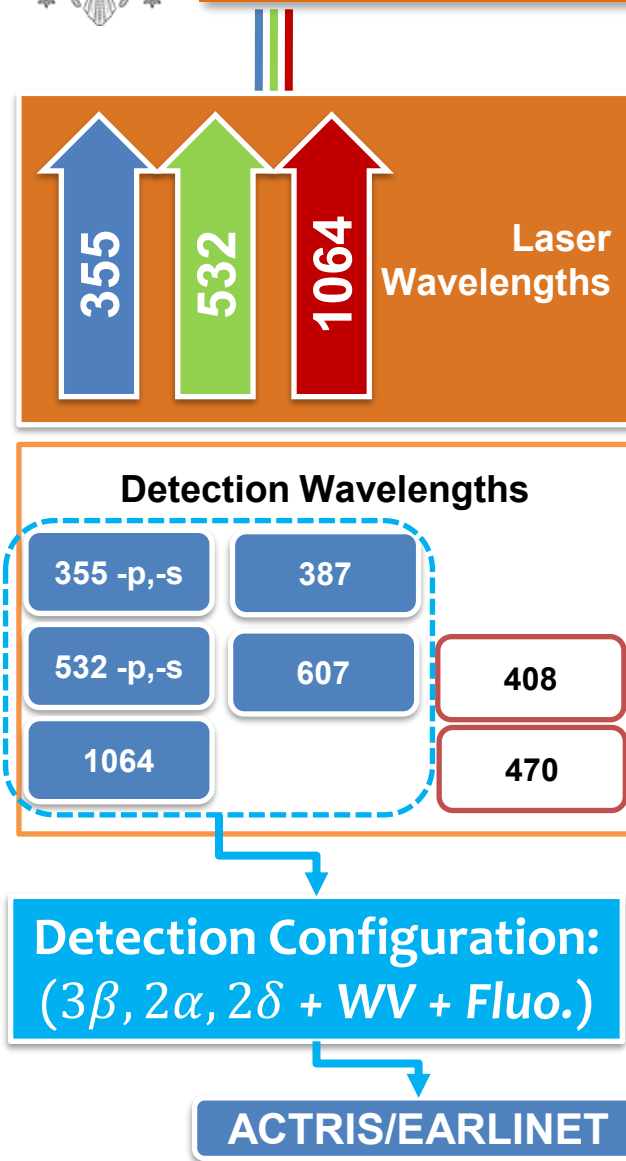



Why 470nm (± 50 nm)?

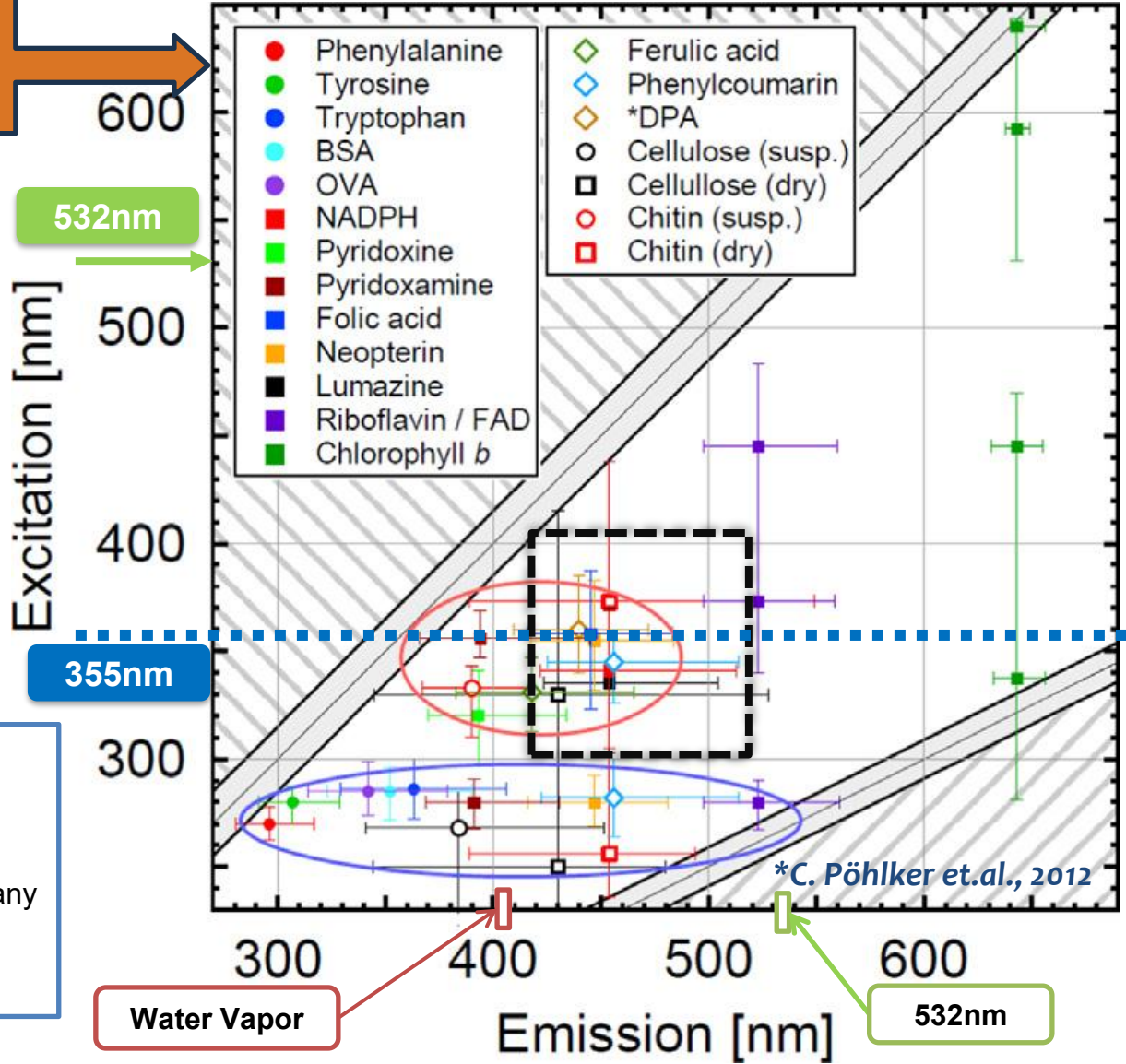

Laser wavelength at 355nm excite many bio-fluorophores

420-520nm band cover emission from many bio-fluorophores

Water Vapor

532nm

*C. Pöhlker et al., 2012



- * Ansmann et al., 1992
- ** Veselovskii et al., 2022
- *** Stachlewska et.al. 2017

Lidar Equations

Lidar Equations (Elastic, Raman)*

$$P_L(z) = K_L \frac{O(z)}{z^2} [\beta_L^a(z) + \beta_L^m(z)] \times \exp \left\{ -2 \int_0^z [\alpha_L^a(\xi) + \alpha_L^m(\xi)] d\xi \right\}$$

$$P_R(z) = K_R \frac{O(z)}{z^2} N_R(z) \frac{d\sigma_R(\pi)}{d\Omega} \times \exp \left\{ - \int_0^z [\alpha_L^a(\xi) + \alpha_L^m(\xi) + \alpha_R^a(\xi) + \alpha_R^m(\xi)] d\xi \right\}$$

Optical Products
(3β, 2α, 2δ)

Lidar Ratio → $S(\alpha_\lambda, \beta_\lambda)$
Angstrom Exponent → $A_\alpha(\alpha_{\lambda_1}, \alpha_{\lambda_2})$
Aerosol Optical Depth → $AOD(\alpha_\lambda)$

Lidar Equations (Fluorescence)**

$$P_F = O(z) \frac{1}{z^2} T_L \int_{\lambda_{\min}}^{\lambda_{\max}} \int_{r_{\min}}^{r_{\max}} C_F(\lambda) \times \frac{dN(r)}{dr} \times \frac{d\sigma_F}{d\lambda}(\lambda, r) \times \exp \left\{ - \int_0^z [\alpha_L^a(\xi) + \alpha_L^m(\xi)] d\xi \right\} dr d\lambda$$

$$\beta_F = \frac{C_R P_F}{C_F P_R} N_R \sigma_R \frac{T_R}{T_F} \quad 1$$

$$G_F = \frac{\beta_F}{\beta_L} \quad 2$$

Fluorescence Capacity

Water Vapor Mixing Ratio***

$$WVMR(z) = \frac{K_{387} P_{R407}}{K_{407} P_{R387}} \times \exp \left\{ \int_0^z [\alpha_{407}^{total}(\xi) + \alpha_{387}^{total}(\xi)] d\xi \right\}$$

Relative Humidity: RH(z)



Flow chart of data processing and analysis

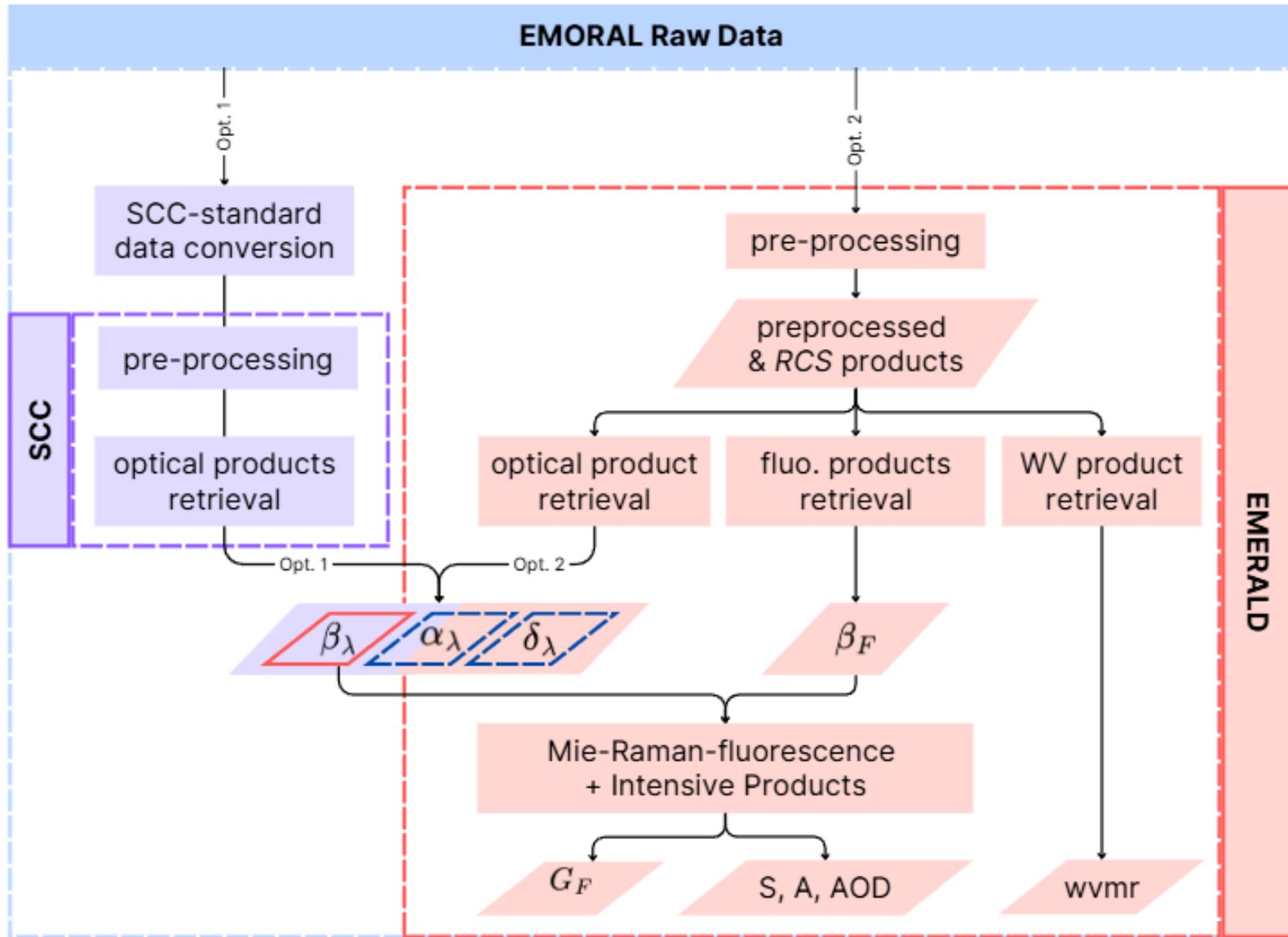

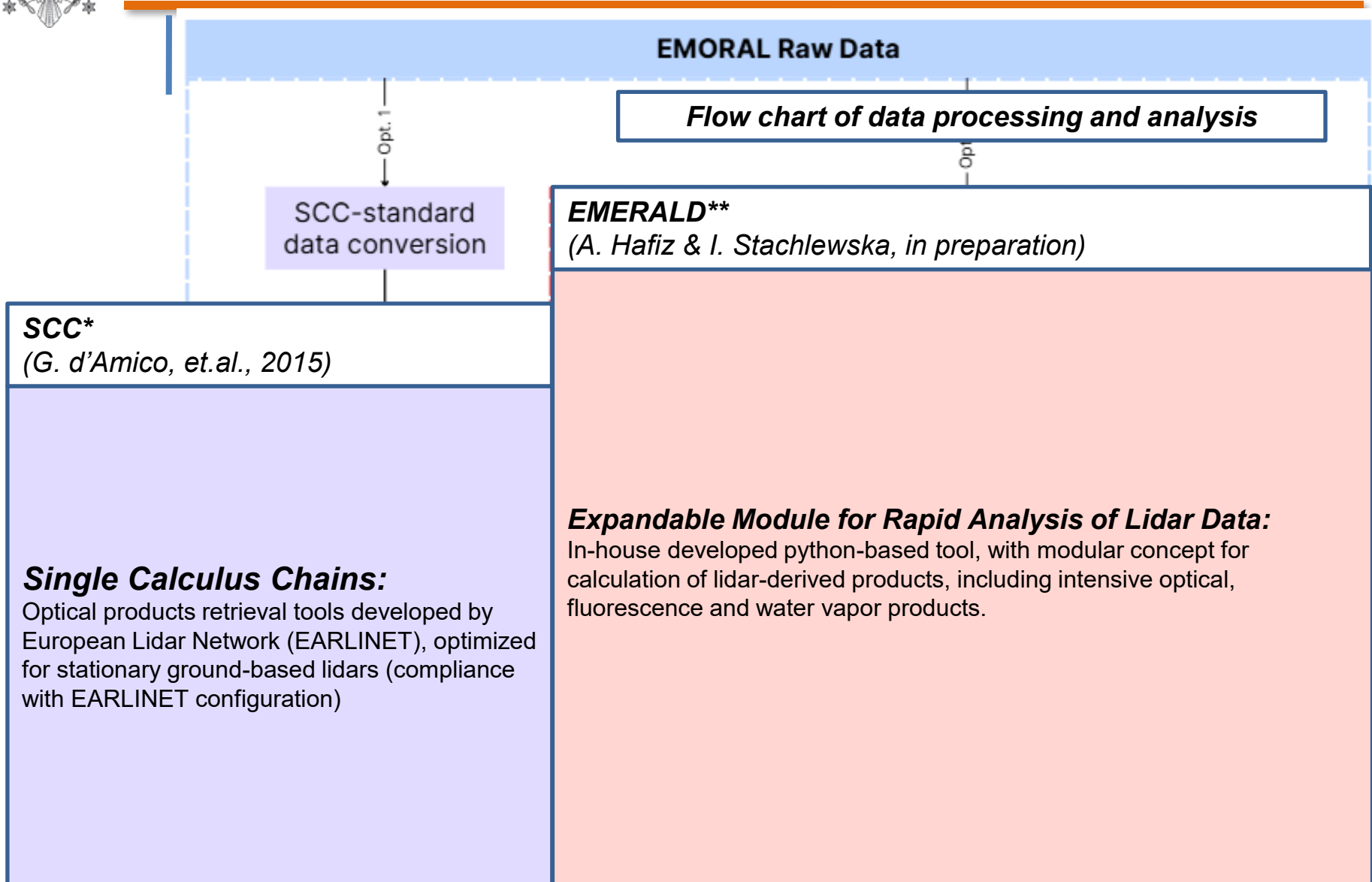

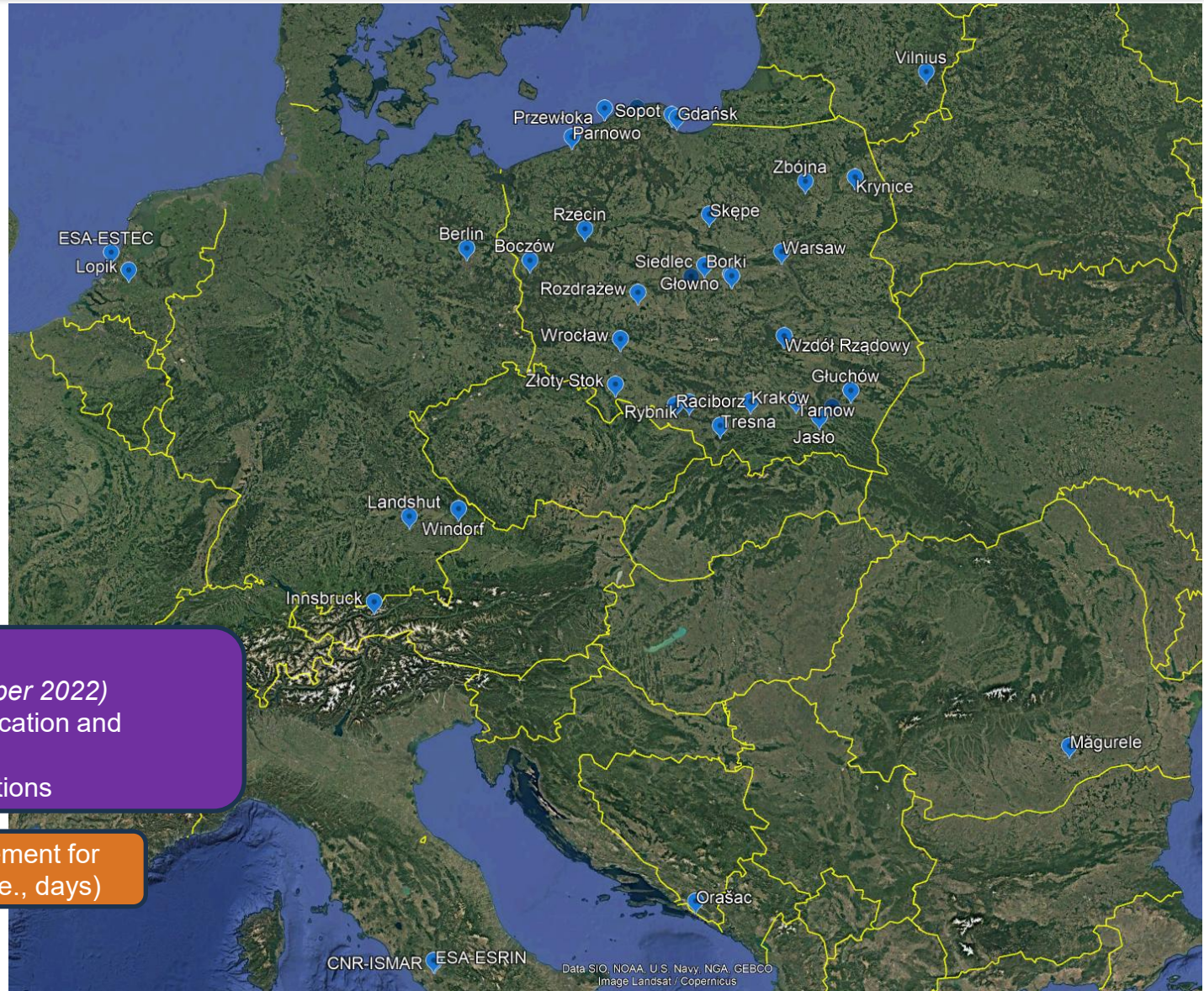

57 field campaigns:

Since fluorescence (September 2022)

- Different geographical location and condition
- Different seasonal conditions

Including short-term measurement for EarthCare cal/val activities (i.e., days)



For simplicity, sites were grouped measurement sites into urban and rural categories using a broad environmental classification:

- **urban** includes locations influenced by city emissions
- **rural** refers to sites outside major urban influence and more representative of background conditions

What we characterize:

- Fluorescence backscatter signal (high or low)
- Fluorescence backscatter & Water Vapor correlation
- Aerosol Types based on Fluorescence

Applied constrains:

- 1) Aerosol within boundary layer only
Upper cut off at boundary top
- 2) Lower Cut off at 500m

Mind that:
Raman, Water Vapor, and Fluorescence
only at Nighttime



- Results -

Number of measurements for each category

Season/Type	Urban	Rural
Winter	5	3
Spring	6	6
Summer	12	11
Fall	7	7

***We only present part of these datasets
Full datasets analysis will be included in publication under preparation***

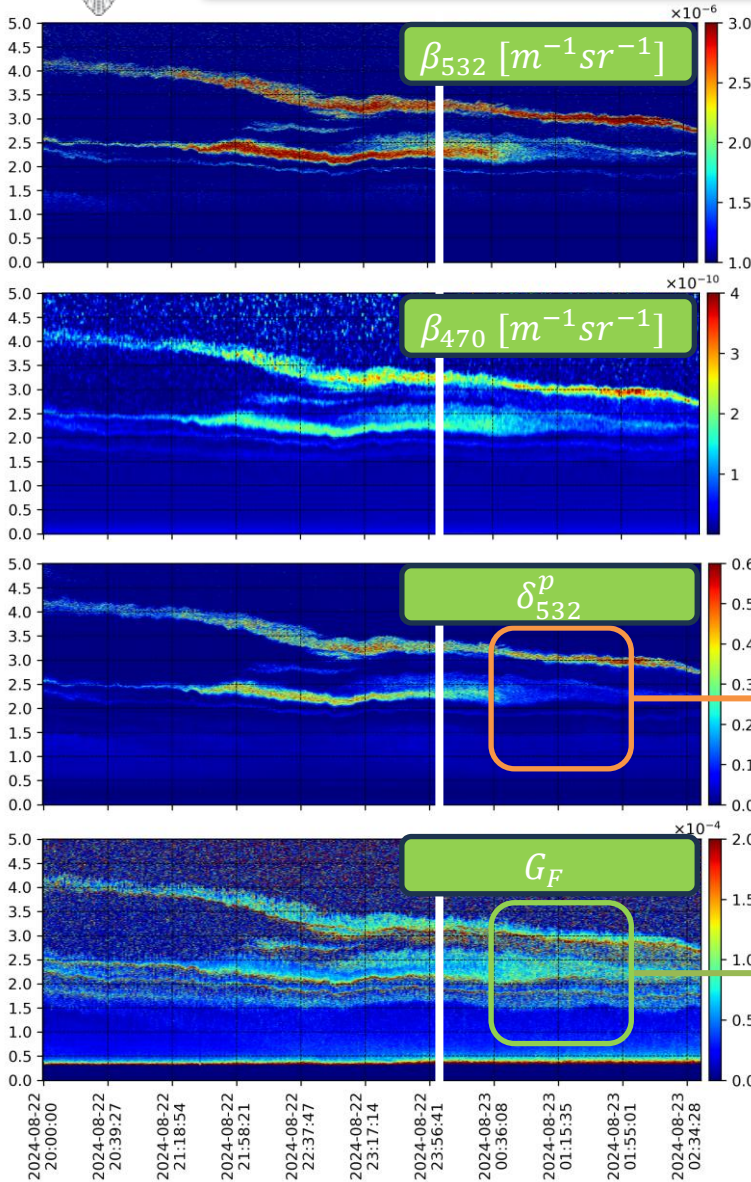

Urban (Summer)
Wroclaw, Poland

At first:
No obvious no obvious added values
But,
If we look closer to δ_p & G_F
We can see the difference

More visible example in other case ...

**High spatio-temporal resolution quasi products*

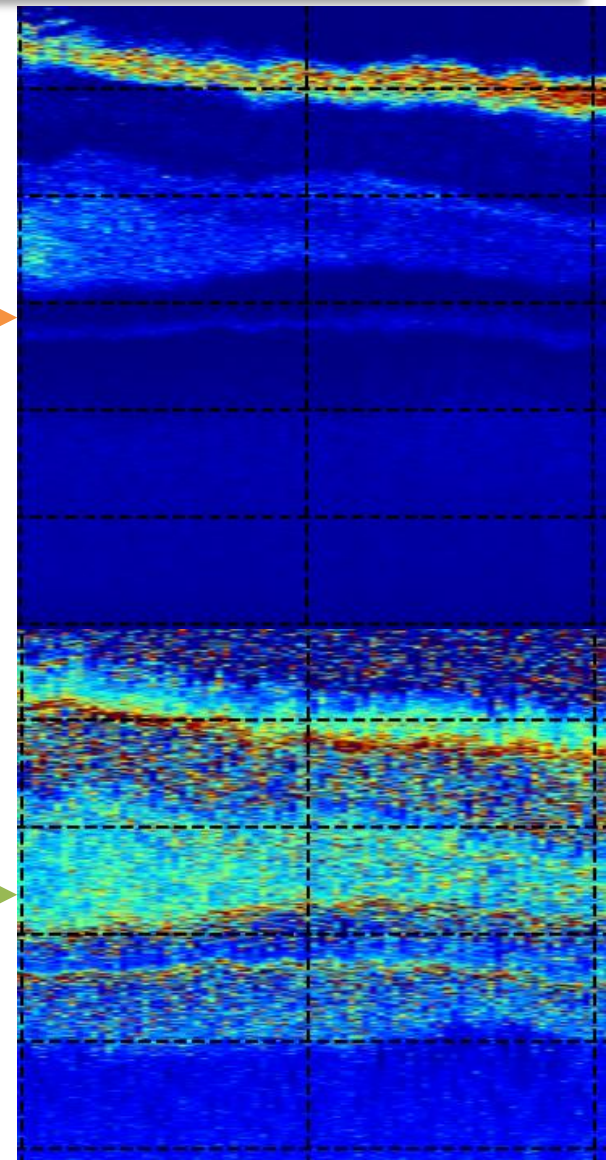



Rural (Summer)
Uniejow, Poland

Case 1.

We observed quite a strong signal at elastic parameters (β_{532} & δ_p^{532}) and no fluorescence signals
→ High depolarization indicate non-spherical aerosols

Case 2.

We observed quite weak β_{532} and low depolarization, δ_p^{532} and strong fluorescence signals
→ Indicating the layer could be bio-aerosol

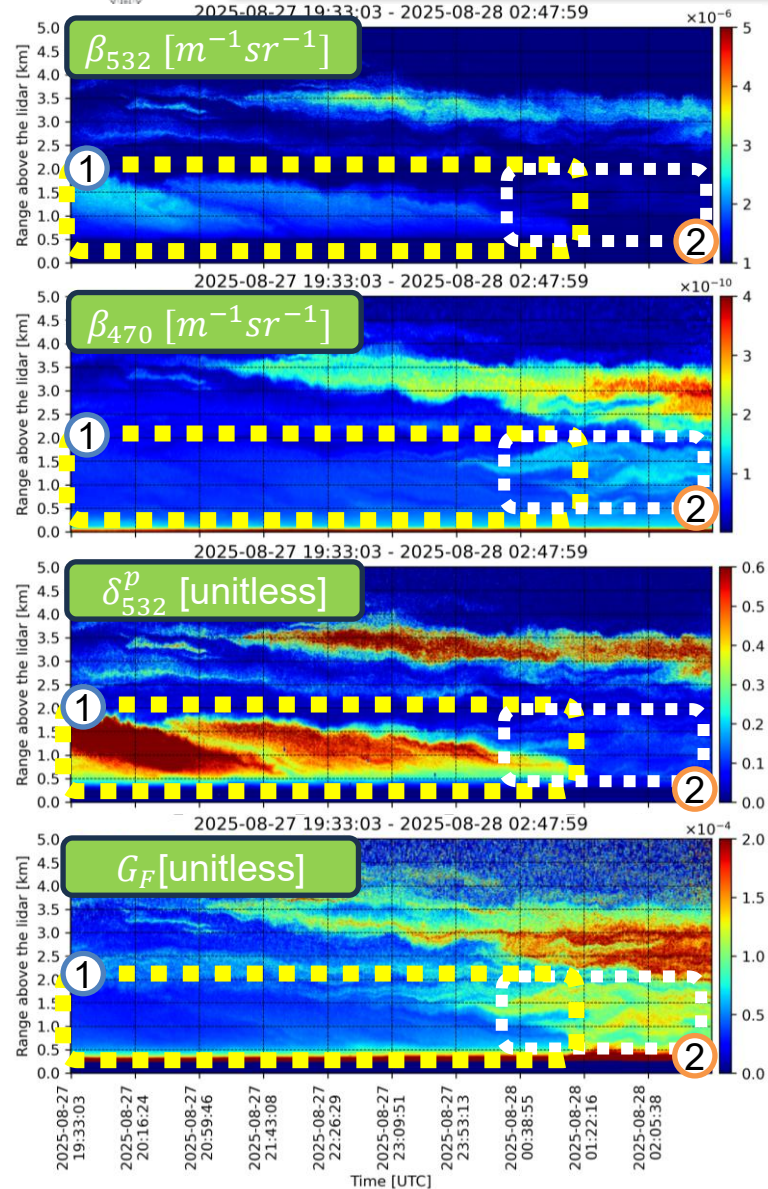



Products - Vertical Profiles

Urban (Summer)

Wroclaw, Poland

23 August 2024

01:00 – 02:00 UTC

Retrieval & plotting:

- 1 hour temp. averaging
- Additional cut-off applied, i.e., if error > 50% (not applied to β_p^{470} & G_F yet)

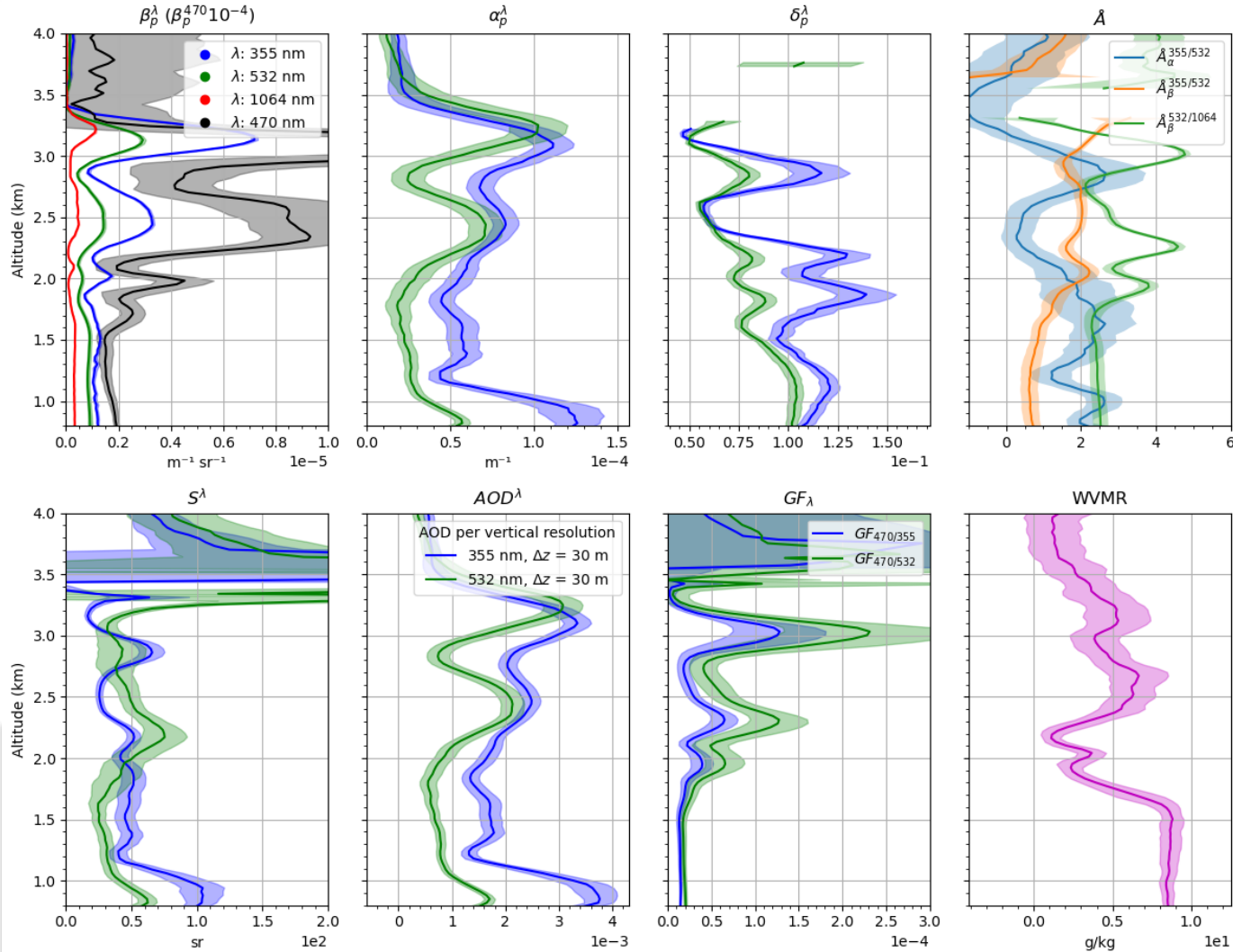

Legends

β : backscatter coefficients

α : extinction coefficients

δ : depolarization ratios

S: lidar ratios

AOD: Aerosol Optical Depth

GF: Fluorescence Capacity

\AA : Angstrom Exponents

WVMR: water vapor mixing ratio



Layer Average Properties

Dataset Note:

- Nighttime mean
- EMERALD product only (high vertical temporal resolution)

Fluorescence backscatter:

Both Fall & Winte campaigns have low β_p^{470} , with winter case shown more frequent variability

Water Vapor:

Both Fall & Winte campaigns have moderate values, with variability observed in both season

Note: Some datasets show <1 due to dataset calculated with older version of EMERALD → Need reprocessing!

Fall Campaigns

Winter Campaigns

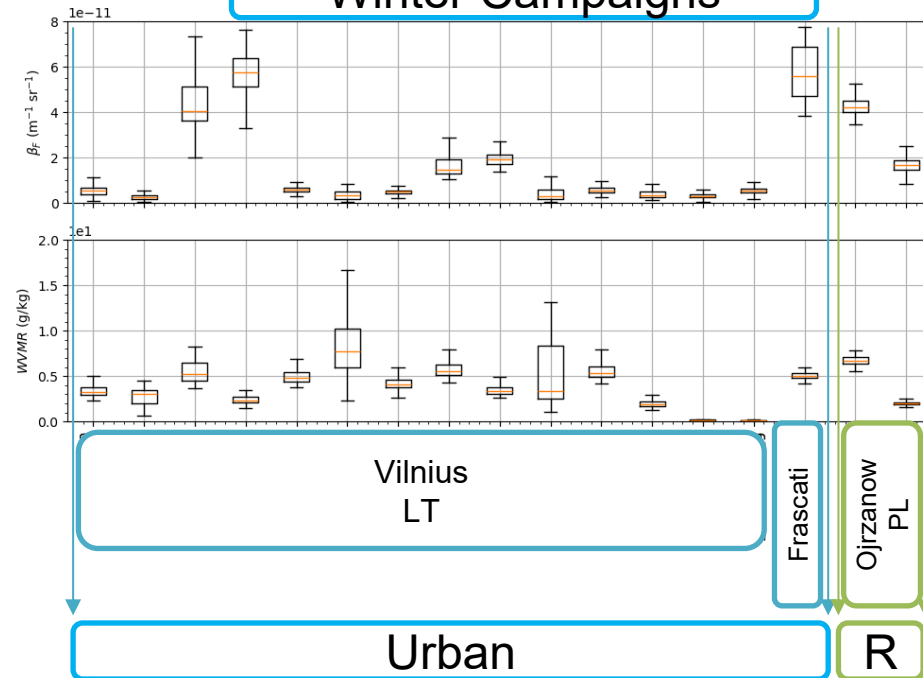
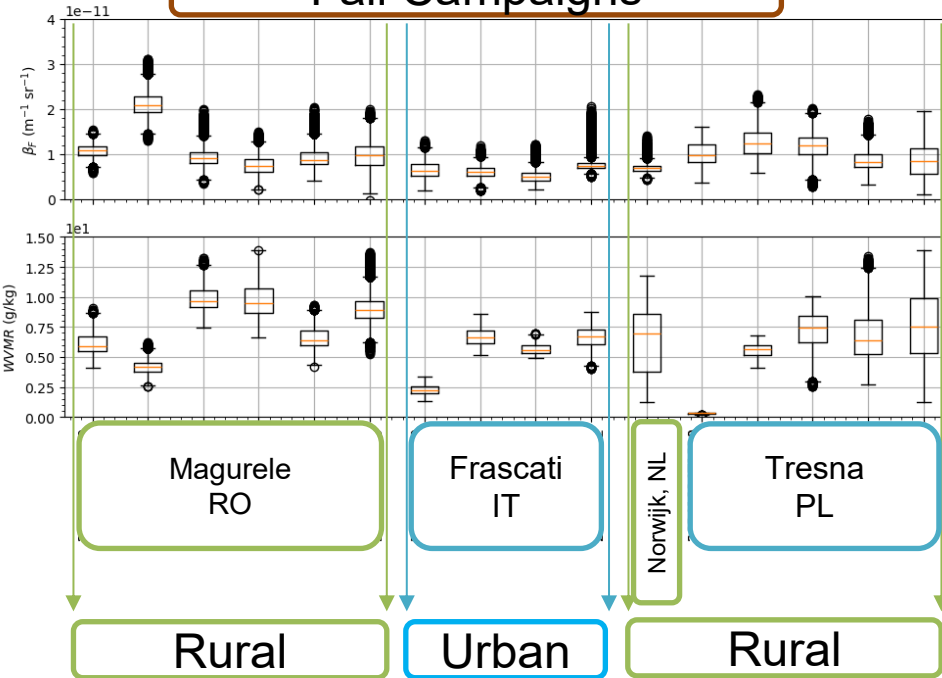

Mind the y-axis scale



Layer Average Properties

Dataset Note:

- Nighttime mean
- EMERALD product only (high vertical temporal resolution)

Fluorescence backscatter:

Summer campaign, shown large different between rural and urban
Spring, shown low values

Water Vapor:

Summer campaigns have moderate values
Spring campaigns → dry condition

Note: Some datasets show <1 due to dataset calculated with older version of EMERALD → Need reprocessing!

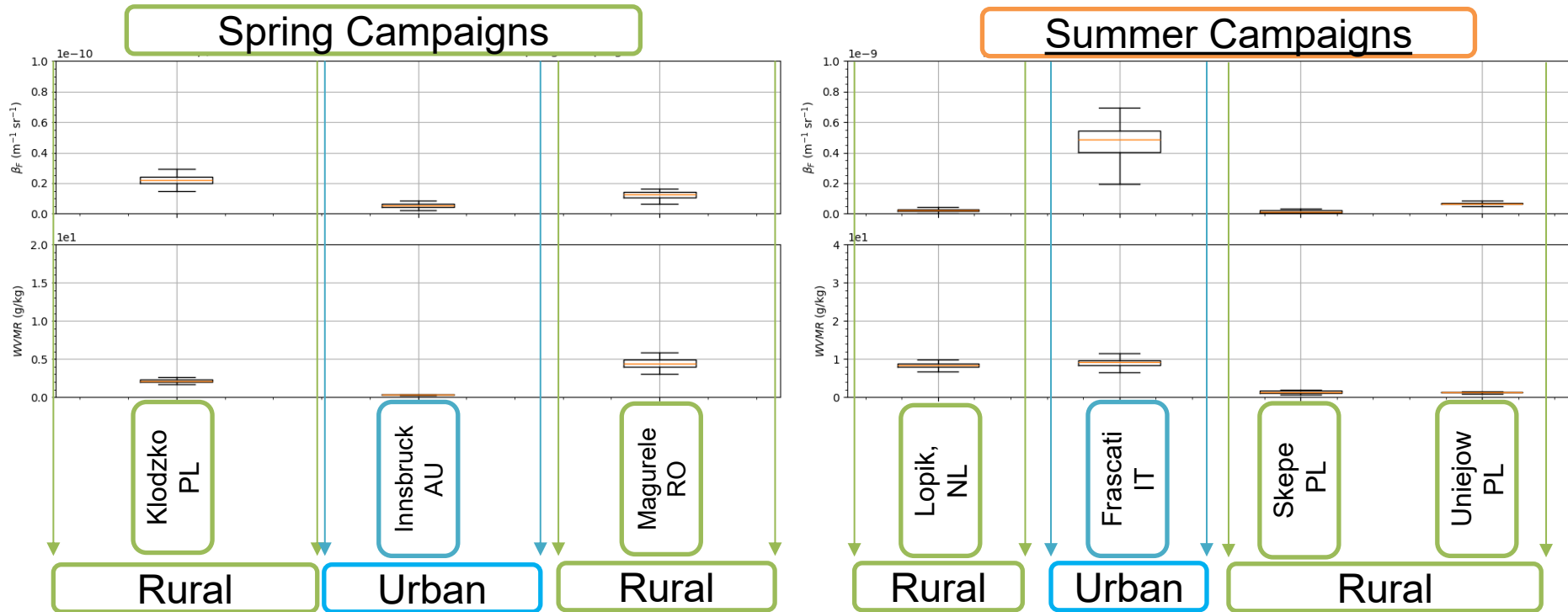

Mind the y-axis scale



Aerosol Typing (example)

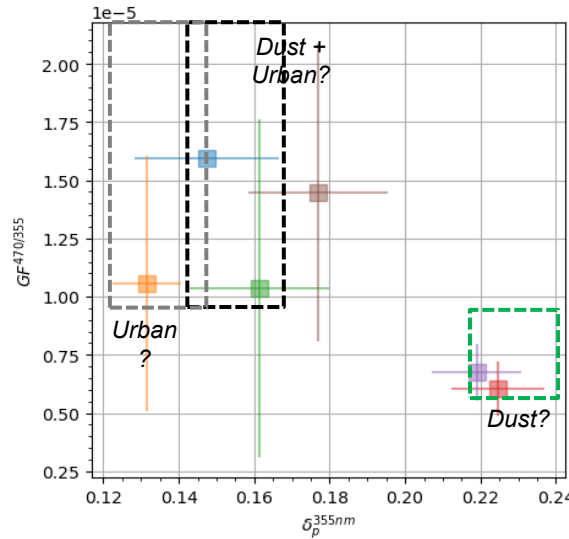
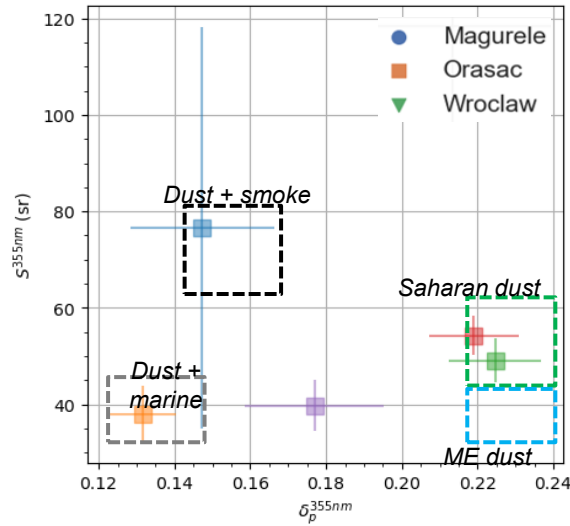

Magurele, Romania (Fall)
 Orasac, Croatia (Fall)
 Wroclaw, Poland (Summer)
 Frascati, Italy (Summer)

Nighttime mean

The squared ranges based on:
 * Veselovskii et al., 2022
 ** A. Floutsi et al., 2013; D. Wang et al., 2020

Plan:
 Typing validation across multiple parameters, GF, S, δ_p , AE, etc.
 Target to build summary table, consisting of observed aerosol type across different location

Season/Type	Urban	Rural
Winter
Spring
Summer	dust, dust+urban	
Fall		urban, dust+marine



- We started a study to what Fluorescence-Mie-Raman Lidar (FLUMIRA) can reveal about **aerosols across seasons and cities**
- We have shown how fluorescence can provide different information from Mie-Raman Lidar
- With current analyzed datasets, **temporary conclusion**:
 - Both Fall & Winter campaigns have low β_p^{470} , with winter case shown more frequent variability
 - Fall campaigns: Rural sites shown higher fluorescence signals (but still in low regime)
 - Both Fall & Winter campaigns have moderate values
 - Summer campaign, shown large β_p^{470} different between rural and urban
 - Spring campaigns show low β_p^{470}
 - Water Vapor indicate Summer campaigns have moderate values, Winter campaigns mainly in dry condition
- Water vapor and fluorescence correlation: No conclusive correlation observed, due to limited calculated data points
- Fluorescence capacity, G_F allows for new typing scheme to complement existing approaches

Plan:

- To analysis the rest of datasets, and extract the conclusion
- To optimize the categorization of datasets, i.e., separating coastal area
- Optimization in the data analysis tool



I thank the RS-Lab Team at the University of Warsaw for helping with performing the EMORAL measurements.

RS-Lab Team:

I. Stachlewska, L. Janicka, D.M. Szczepanik, M. Karasewicz, W. Kumala, R. Fortuna, P. Poczta, K. Gabzdyl, I. Okraska, E. Ugboma, A. Hafiz, D. Wang, Z. Rykowska, M. Szczyrba, M. Winikowski and A. Tomczak

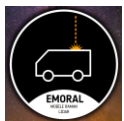



EMORAL development was led by I. Stachlewska (UW) in collaboration with G. Georgoussis (Raymetrics S.A.), V. Freudenthaler (LMU), V. Amiridis (NOA), and G. Tzeremes, D. Schuettmeyer, P. Ribes, J.v.Bismarck (ESA)

We would like to thank the Opto-Electronics section (TEC-MME) at the European Space Research and Technology (ESTEC) of the European Space Agency (ESA) for providing the ESA Mobile Raman Lidar (EMORAL) that was rebuild within “Technical assistance for Polish Radar and Lidar Mobile Observation System (POLIMOS)” funded by ESA-ESTEC Contract no. 4000119961/16/NL/FF/mg.

The ACTRIS National Facility in Warsaw is operationally supported since January 2024 by the Ministry of Science and Higher Education of Poland within ACTRIS-ERIC (grant no.: 2024/WK/04)

For support with QA/QC we thank D. Nicolae, L. Belegante ACTRIS-CARS at INOE, L. Mona, G. D'Amico EARLINET-SCC at CNR-IMAA, and A. M. Fjaeraa EVDC-ESA for the assistance with data provision with EarthCARE cal/val

The operational support of EMORAL lidar during the filed campaigns has been assured by various teams:

UW: I. Stachlewska, L. Janicka, D.M. Szczepanik, M. Karasewicz, W. Kumala, R. Fortuna, P. Poczta, I.Okraska, D. Wang, A. Hafiz, K. Gabzdyl, Z. Rykowska, M. Szczyrba, M. Winikowski

PULS: B. Chojnicki, P. Poczta, K. Harenda; **AGH:** M. Zimnoch, J. Nęcki, J. Bartyzel; **INOE:** L. Belegante, J. Vasilescu, A. Nemuc, D. Nicolae; **FTMC:** S. Byčenkienė, S. Pauraitė-Dudek, D. Valiulis; **UWR:** A. Drzeniecka-Osiadacz, T. Sawiński;

UŚ: M. Jabłońska; **IPIŚ-PAN:** K. Klejnowski, L. Jaworek; **NOA:** V. Amiridis, P. Kokkalis.